



**MEP**  
**ENGINEERING**  
**ELECTRO MECHANICAL W.L.L**  
**MECHANICAL - ELECTRICAL - PLUMBING**



**الهندسية إلكترو ميكانيكال ذ.م.م**

**ENGINEERING ELECTRO MECHANICAL W.L.L**

Tel/ Fax: (+974) 44148236, Mob: (+974) 55690066, P.O.Box: 91111 Doha – Qatar. CR.No: 26935/16  
E-Mail: info@mepqatar.com Web: www.mepqatar.com



## About Us

*MEP ENGINEERING ELECTRO MECHANICAL was founded in the year 2010 in Doha, Qatar. help you succeed with top, trusted brands suppliers of Water Pumps, Water Heaters, Water Filters, Water Chillers, Fire Fighting, Fire Alarm & Plumbing OS & Y Gate Valves, Alarm Gate Valves, NRV, Gi Pipe, Gi Fighting, & Water Metter Cabint services that deliver the performance, quality and convenience that you deserve.*

*With the experienced and support of dedicated, professional workforce and services combined with expert knowledge, processes and systems, MEP has succeeded to help clients & customers achieve optimum value to business making.*

*Our futuristic vision and hard work gives us opportunities for continuing growth and profitability.*

*Maintaining our dedication to the government & private sectors, MEP will continue to improve supply of quality products on time ,expand our capabilities, increase our efficiency, and elevate the superior level of customer service to heighten our standard of execllance and existence.*



*Our sincere commitment to community at large, social responsibility towards environmental values etc., provides us immense energy in offering ethical, economical, and premier quality of products to our clients .*



*To seize the opportunities of tomorrow and creat a future that will make us a leader positive company.*

*To be on the lookout for and shape the opportunities to get the first-mover advantage and remain ahead of competition. The opportunitie could exist in emerging technology, new business models, value creation, customer service, new products services or business and financing options.*

*To reduce costs and enhahce revenues coupled with finance prudence to galvanize core and attractive investment option.*



# CONTENTS

## 1- FIRE FIGHTING

◆ GI & Black Pipe SCH 20, 40, 80 .....	2
◆ National Grooved Fitting .....	3
◆ BIS Threaded Fitting .....	5
◆ OS & Y Gate Valve 200 , 250 , 300 PSI .....	6
◆ NRS Gate Valve 200 , 250 , 300 PSI .....	7
◆ Grooved & Flanged Chek Valve .....	8
◆ Alarm Gate Valve 200 , 250 , 300 PSI .....	9
◆ Grooved Buterfly Valve & Y Strainer .....	10
◆ Breeaching Inlet & Landing Valve & Fire Hydrant .....	11
◆ Fire Hose Real & Cabint .....	12
◆ ABC & CO2 Fire Extinguisher .....	13
◆ Fire Sprinkler Systems .....	14
◆ Fire Sprinkler Monitoring & Fire Rated Doors .....	16

## 2- FIRE ALARM SYSTEM

◆ Exit & Emergency Light .....	17
◆ Fire Alarm Control Panal , Smoke & Heat Detector .....	17

## 3- ITT LOWARA WATER PUMP

◆ Vertical Type Multi Stage Pump .....	18
◆ Horizontal Type & Submersible Drainage & Sewage Pump .....	19
◆ Circulation Pump .....	20

## 4- WATER HEATERS

◆ Ariston Water Heater .....	20
◆ Bradford White Water Heater .....	21
◆ A.O.Smith Water Heater .....	22

## 5-WATER FILETERS

◆ Pentair, Fleck Water Filtration Systems .....	23
---	----

## 6-WATER CHILLER

◆ Blue Star , Reem Water Chiller .....	24
--	----

## 7- PROJECTS

# 1- Fire Fighting Fittings

## Gi & Black Pipe



### Round Tubes

**Outside Diameter :** 21.3mm-355.6mm

**Thickness Range :** 0.7mm-8.0mm

**Length :** 3.0 meter to 12.0 meter

#### APPLICATIONS

- Liquid Transmission
- Idlers
- Mechanical and General Engineering
- Structural
- Water and Sewage
- Water Wells
- Fire Protection
- Fencing
- **& Many more...**

#### PRODUCTION STANDARDS

- IS:1239(Part-I)/2004, BS:1387-1990
- DIN2439, DIN2440, DIN2441, DIN2444
- EN10255:2004, EN10240:1998
- IS:9295-1983
- IS:3601-1984
- IS:1161-1998
- IS:3589/2001
- IS:4270.2001
- ASTM A-53 GR A&B SCH 20/40/80
- ASTM A-795
- ASTM A-135

#### TESTS PERFORMED

- Hydrostatic Test
- Eddy Current Test
- Flattening/Flaring Test/Bend Test
- Chemical Analysis
- Other Tests as required by the Standard

#### FINISHING OPERATIONS

- Plain End
- Threaded and Coupled
- Grooved
- Cut Lengths

#### SURFACE PROTECTION

- Black (Self Colored Uncoated)
- Outside Protective Coating-Oil/Varnish
- Hot Dip Galvanised
- Pre-Galvanised



**SURYA**  
STEEL PIPES



in  
**WINDMILLS**



Black (SELF COLORED UNCOATED)



Oiled/Varnish



Hot Dip Galvanised



Pre-Galvanised

**NOTE:** For details please refer specification sheet.

# Fire Fighting Fittings

## Grooved Fighting



*"a step up in value, a step down in cost"*

### INDUSTRY AND GOVERNMENT STANDARDS & APPROVALS



**ISO 9001**



**PED 97/23/EC**

(ABS)	American Bureau of Shipping
(ANSI)	American National Standards Institution
(AWWA)	American Water Works Association : C-606
(API)	American Petroleum Institute
(ASHRAE)	American Society of Heating, Refrigeration & Air Conditioning Engineers
(ASME)	American Society of Mechanical Engineers
(ASTM)	American Society of Testing & Materials
(BBA)	British Board of Agreement
(BOCA)	Building Officials & Code Administrators
(BMI)	Bureau of Marine Inspection
(BPR)	Bureau of Public Roads
(CDC)	Civil Defense Certificate, Dubai
(COA)	Corps of Engineers - CEGS 15000
(FAA)	Federal Aviation administration; HVAC, Plumbing, Fire Protection
(FHA)	Federal Housing Administration
(FM)	Factory Mutual Engineering Corp.
(IAPMO)	International Association of Plumbing & Mechanical Officials
(MEA)	Materials and Equipment acceptance
(NAVFAC)	Naval facilities Engineering Command: NFGS 15000 Series
(NFPA)	National Fire Protection Association
(NSF)	NSF International
(SBCCI)	Southern Building Code Congress International
(TVA)	Tennessee Valley Authority; Fire Protection, Storm drains
(UL)	Underwriter's Laboratories, Inc.
(ULC)	Underwriter's Laboratories of Canada
(PED)	Pressure Equipment Directive

#### WORLDWIDE

(AS)	AS 4041 - 1992 Australian Standard (3.24.10)
(BV)	Bureau Veritas
(DNV)	Det Norske Veritas
(DVGW)	Deutscher Verein des Gas-und Wasserfaches

# Fire Fighting Fittings

## Grooved Fighting



"a step up in value, a step down in cost"

### RIGID COUPLING STYLE 2

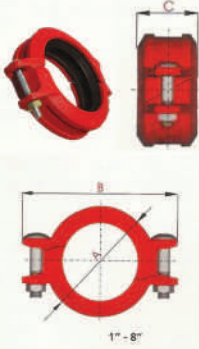

Pipe Nominal Size	Actual Size in./mm	Part Number	Max. Working Pressure psi / MPa	Allow Pipe End Separation in./mm	Dimensions (inch / mm)			Approx. Wt. Each Lb./kg
					A	B	C	
1"	1.315 / 33.4	02100	500 / 3.5	0.10 / 2.5	2.19 / 55.6	3.54 / 90.0	1.72 / 43.8	1.2 / 0.5
1 1/4"	1.660 / 42.3	02125	500 / 3.5	0.10 / 2.5	2.56 / 65.0	3.90 / 99.0	1.73 / 43.8	1.2 / 0.5
1 1/2"	1.900 / 48.3	02150	500 / 3.5	0.10 / 2.5	2.80 / 71.8	4.21 / 107.0	1.73 / 43.8	1.3 / 0.6
2"	2.375 / 60.3	02200	500 / 3.5	0.10 / 2.5	3.29 / 83.8	4.72 / 120.0	1.79 / 45.3	1.5 / 0.7
2 1/2"	2.875 / 73.0	02250	500 / 3.5	0.10 / 2.5	3.83 / 97.8	5.28 / 134.0	1.79 / 45.3	1.8 / 0.8
3"OD	3.000 / 76.2	02290	500 / 3.5	0.10 / 2.5	3.96 / 100.5	5.39 / 137.0	1.79 / 45.3	2.1 / 1.0
3"	3.500 / 88.9	02300	500 / 3.5	0.10 / 2.5	4.49 / 114.0	5.98 / 151.0	1.79 / 45.3	2.4 / 1.1
4"	4.500 / 114.3	02400	500 / 3.5	0.16 / 4.1	5.83 / 148.0	7.20 / 183.0	1.99 / 45.3	3.7 / 1.7
5"	5.563 / 141.3	02500	300 / 2.1	0.16 / 4.1	6.91 / 175.5	8.66 / 220.0	1.99 / 45.3	4.6 / 2.1
6"	6.625 / 168.3	02600	300 / 2.1	0.16 / 4.1	8.07 / 205.0	9.80 / 249.0	1.99 / 45.3	6.0 / 2.7
6 1/2"OD	6.500 / 165.1	02650	300 / 2.1	0.16 / 4.1	7.91 / 201.0	9.69 / 246.0	1.99 / 45.3	5.5 / 2.5
8"	8.625 / 218.1	02800	300 / 2.1	0.19 / 4.8	10.26 / 261.0	12.40 / 315.0	2.32 / 53.1	11.9 / 5.4

**Notes**

Allowable pipe end separation is for cut groove pipe and for roll groove, figures will be one-half of the values listed and there are at time of initial pressurisation. Ø - Bolts and Nuts are Galvanized +- Maximum pressure including surges and maximum end loads from all internal and external forces, to which a joint could be subject under normal working conditions. This rating provides a nominal safety factor of 1.5 times working pressure based on standard weight steel pipe, cut or roll groove to pipe end preparation specification. Maximum joint working pressure may be subjected to a one time field test of 1.5 times the figures indicated. Contact our Engineering Department for performance on other pipes, and to request the approvals cut sheet. Refer to installations and groove specifications when assembling any grooved product. For dry system, TRI Seal gasket is recommended. To order galvanized finish, place "G" after the part number. EPDM based gasket is supplied as standard. For other gasket contact us.

### GROOVED FITTINGS - SHORT PATTERN

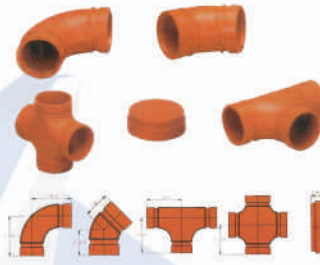

**FLOW DATA**  
Frictional Resistance  
(Represented as equivalent Straight Pipe in Ft./m)

Nominal Size inches	90° Elbow		45° Elbow		Tee	
	STD	XS	STD	XS	Branch	Run
1	1.7	1.4	0.9	0.8	1.4	4.0
1 1/4	2.7	1.8	1.2	1.0	1.8	4.2
1 1/2	3.7	2.5	1.3	1.3	2.7	5.5
2	4.7	3.2	1.7	1.6	3.6	8.2
2 1/2	6.1	3.9	2.1	2.0	4.5	10.1
3	7.5	4.5	2.2	2.2	5.4	12.4
3 1/2	8.9	5.1	2.3	2.3	6.3	14.7
4	10.3	5.8	2.4	2.4	7.2	17.0
4 1/2	11.7	6.5	2.4	2.4	8.1	19.3
5	13.1	7.2	2.5	2.5	9.0	21.6
5 1/2	14.5	8.0	2.5	2.5	10.0	24.0
6	15.9	8.8	2.6	2.6	11.0	26.4
6 1/2	17.3	9.6	2.6	2.6	12.0	28.8
7	18.7	10.4	2.7	2.7	13.0	31.2
8	20.1	11.2	2.7	2.7	14.0	33.6

Flow data is based upon the pressure drop of Sch. 40 Pipe.

Pipe Nominal Size	Actual Size	90° Elbow - No.F105			45° Elbow - No.F106			Equal Tee - No.F107			Cross - No.F135			End cap - No.F155		
		Part Number	C to E	Approx. Wt. Lb./kg	Part Number	C to E	Approx. Wt. Lb./kg	Part Number	C to E	Approx. Wt. Lb./kg	Part Number	C to E	Approx. Wt. Lb./kg	Part Number	C to E	Approx. Wt. Lb./kg
1 1/4"	1.660	103125	2.25	0.9	106125	1.75	0.5	107125	2.25	1.0	155125	1.00	0.4	155125	1.00	0.4
1 1/2"	1.900	105150	2.50	1.1	108150	1.75	0.9	107150	2.50	1.5	155150	1.00	0.5	155150	1.00	0.5
2"	2.375	105200	2.75	1.3	106200	2.00	1.1	107200	3.00	2.0	155200	1.00	0.7	155200	1.00	0.7
2 1/2"	2.875	105250	3.00	1.5	106250	2.25	1.3	107250	3.00	2.5	155250	1.00	0.9	155250	1.00	0.9
3"	3.500	105300	3.25	1.7	106300	2.50	1.5	107300	3.25	3.0	155300	1.00	1.1	155300	1.00	1.1
4"	4.500	105400	4.00	2.1	106400	2.75	1.7	107400	4.00	3.5	155400	1.00	1.3	155400	1.00	1.3
5"	5.563	105500	4.88	2.5	106500	3.00	2.1	107500	4.88	4.5	155500	1.00	1.5	155500	1.00	1.5
6"	6.625	105600	5.50	2.9	106600	3.25	2.5	107600	5.50	5.5	155600	1.00	1.7	155600	1.00	1.7
6 1/2"	6.500	105650	5.50	2.9	106650	3.25	2.5	107650	5.50	5.5	155650	1.00	1.7	155650	1.00	1.7
8"	8.625	105800	6.88	3.2	106800	3.75	2.9	107800	6.88	6.5	155800	1.00	2.1	155800	1.00	2.1

### CONCENTRIC REDUCER STYLE 140

### NIPPLES (STEEL) STYLE 35

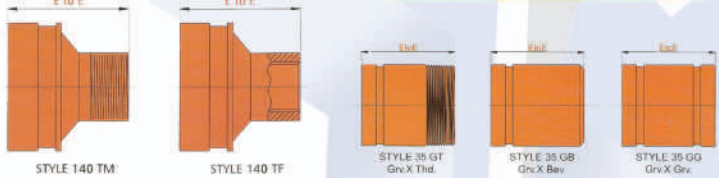

NOMINAL SIZE	E to E Inch/mm	APPROX. Wgt. Ea Lb/kg
2"x1"	2.5/63.5	1.39/0.632
2"x1-1/4"	2.5/63.5	0.74/0.338
2"x1-1/2"	2.5/63.5	0.74/0.338
2-1/2"x1	2.5/63.5	1.14/0.520
2-1/2"x1-1/4"	2.5/63.5	1.14/0.520
2-1/2"x1-1/2"	2.5/63.5	1.14/0.520
2-1/2"x2"	2.5/63.5	1.14/0.520
3"ODx1"	2.5/63.5	1.14/0.520
3"ODx1-1/4"	2.5/63.5	1.14/0.520
3"ODx1-1/2"	2.5/63.5	1.14/0.520
3"ODx2"	2.5/63.5	1.14/0.520
3"x1"	2.5/63.5	1.59/0.725
3"x1-1/4"	2.5/63.5	1.59/0.725
3"x1-1/2"	2.5/63.5	1.59/0.725
3"x2"	2.5/63.5	1.38/0.630
4"x1"	3/76.2	2.28/1.036
4"x1-1/4"	3/76.2	2.28/1.036
4"x1-1/2"	3/76.2	2.28/1.036
4"x2"	3/76.2	2.28/1.036
6"x1"	4/101.6	6.92/3.146
6"x1-1/4"	4/101.6	6.92/3.146
6"x1-1/2"	4/101.6	6.92/3.146
6"x2"	4/101.6	6.92/3.146

NOMINAL SIZE	E to E Inch/mm	APPROX. Wgt. Ea Lb/kg
1"	3/76.2	0.4/0.2
1-1/4"	4/101.6	0.8/0.4
1-1/2"	4/101.6	0.8/0.4
2"	4/101.6	1.2/0.5
2-1/2"	4/101.6	1.9/0.9
3"	4/101.6	2.5/1.1
4"	6/152.4	5.5/2.5
5"	6/152.4	7.4/3.4
6"	6/152.4	9.5/4.3
8"	6/152.4	14.2/6.4
10"	8/203.2	27.0/12.2
12"	8/203.2	33.0/15.0

### HOSE NIPPLE STYLE 80

Size Inches / millimeters	E to E Inches / mm	Weight Each Lbs / kg
1	3.25	0.4
25	83	0.2
1/4	3.63	0.6
3/8	92	0.3
1/2	4.00	0.8
40	102	0.4
2	4.63	1.1
50	118	0.5
2 1/2	5.50	2.0
65	140	0.9
3	6.00	3.2
80	152	1.5
4	7.25	4.9
100	184	2.2

### MECHANICAL BRANCHLETS STYLE 135

- Style 135 Mechanical tee serves the same function as Style 13 and assures full pipe support by wrap around ductile iron housing to ASTM A536.
- Cross fitting can be conveniently formed by combining two equal sized upper castings of 135, either the same, or different branch connection sizes.
- Provided with EPDM rubber gasket as standard, suitable for -30°F to 230°F (-34°C to 110°C).

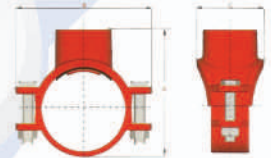

**Performance Data :**

SIZE	Actual Size	Equi Feet / Meters of Pipe
1 1/4 X 1	16.53	
42.2 X 33.4	5.0	
1 1/2 X 1	17.57	
48.3 X 33.4	5.4	
2 X 1	3.43	
60.3 X 33.4	1.1	
2 1/2 X 1	2.76	
73.0 X 33.4	0.8	



Run Size Inch	Outlet Size Inch	Part Number	Max. Working Pressure psi/kPa	Hole Diameter		Dimensions in./mm			Approx. Wt. Each Lb./kg
				Hole Saw	Max. Perm.	A	B	C	
1 1/4	3/8	135125037	500	1.00	1.06	1.75	3.66	2.16	-
	1/2	135125050	500	1.00	1.06	1.75	3.66	2.16	0.3
	3/4	135125075	500	1.00	1.06	1.75	3.66	2.16	0.4
1 1/2	1	135125100	500	1.00	1.06	2.13	3.66	2.16	0.5
	3/8	135150037	500	1.00	1.06	1.86	3.77	2.16	-
	1/2	135150050	500	1.00	1.06	1.86	3.77	2.16	0.4
2	3/4	135150075	500	1.00	1.06	2.24	3.77	2.16	0.5
	1	135150100	500	1.25	1.31	2.10	4.13	2.52	-
	3/8	135200037	500	1.25	1.31	2.10	4.13	2.52	0.4
2 1/2	1/2	135200050	500	1.25	1.31	2.10	4.13	2.52	0.5
	3/4	135200075	500	1.25	1.31	2.36	4.44	2.52	0.6
	1	135200100	500	1.25	1.31	2.48	4.44	2.52	0.6

# Fire Fighting Fittings

## BIS Threaded Fitting

BIS Pipe Fitting Industry Co., LTD.

Galvanized/Black Malleable Iron Pipe Fittings (Class 150) Standard specification :

Standard	AMERICAN	BRITISH	DIN
Design	ANSI/ASME B-16.3 ANSI/ASME B-16.14 ANSI/ASME B-16.39	BS 143 & 1256	EN 10242
Threads	ANSI/ASME B-1.20.1	BS 21	ISO7-1, ISO228-1
Material	ASTM A-197	BS 6681	EN 1562 (EN-GJMB-300-6)
Galvanizing	ASTM A-153	BS 729	DIN 2950
Type	BANDED	BANDED	BEADED



FIG. 90 ELBOWS 90° (L 90)	SIZE (INCH)	a (mm.)	b (mm.)	c	PCS/ INNER	QTY OF INNER	PCS/ MASTER	WT/ MASTER KGS.
	1/8	17.5			50	B12	600	19
	1/4	20.6			35	B12	420	20
	3/8	24.1			25	B12	300	41
	1/2	28.5			50	6	400	43
	3/4	33.3			35	6	210	33
	1	38.1			20	6	120	33
	1-1/4	44.5			20	4	80	32
	1-1/2	49.3			10	3	40	30
	2	57.2			8	4	32	28
	2-1/2	70.0			6	3	18	26
	3	81.0			7	2	14	26
	3-1/2	90.0			6	6	20	6
	4	99.0			6	9	21	6
	5	113.0			6	2	12	2
	6	132.0			6	2	18	2



FIG. 90R RED. ELBOWS (RL)	SIZE (INCH)	a (mm.)	b (mm.)	c	PCS/ INNER	QTY OF INNER	PCS/ MASTER	WT/ MASTER KGS.
	1/4x1/8	18.8	19.3		40	B12	480	22
	3/8x1/8	20.5	21.6		70	12	840	46
	3/8x1/4	22.4	22.9		60	12	720	47
	1/2x1/8	22.0	22.4		40	12	480	39
	1/2x1/4	24.6	24.9		40	12	480	41
	1/2x3/8	26.4	26.2		50	8	400	38
	3/4x1/8	24.1	26.0		50	8	400	44
	3/4x1/4	26.7	27.4		40	8	320	41
	3/4x3/8	28.5	28.7		25	12	300	40
	3/4x1/2	30.5	31.0		30	8	240	35
	1x1/8	28.2	29.7		40	6	240	40
	1x1/4	28.2	31.0		40	6	240	43
	1x3/8	30.0	32.3		40	6	240	38
	1x1/2	32.0	35.5		30	6	180	35
	1x3/4	34.8	36.8		30	6	150	35
	1-1/4x3/8	32.8	35.6		80	2	160	44
	1-1/4x1/2	34.0	38.9		35	4	140	40
	1-1/4x3/4	36.8	41.2		15	8	120	37
	1-1/4x1	40.1	42.4		10	8	80	28
	1-1/4x3/4	36.8	39.0		30	4	120	40
	1-1/2x3/8	33.8	39.0		25	4	100	33
	1-1/2x1/2	35.6	42.2		15	6	90	42
	1-1/2x3/4	36.8	44.5		15	6	90	42
	1-1/2x1	41.9	45.7		10	8	80	34
	1-1/2x1-1/4	46.2	47.8		15	4	60	29
	2x1/2	37.3	43.4		15	4	60	30
	2x3/4	40.6	50.0		10	6	60	31
	2x1	43.5	50.5		14	4	56	32
	2x1-1/4	48.3	53.3		10	4	40	27
	2x1-1/2	51.3	54.9		10	4	40	29
	2-1/2x3/4	43.8	59.4		10	4	40	36



TS 11 EN 10242

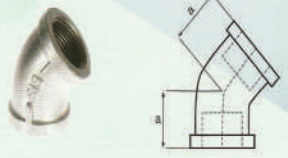

FIG. 120 ELBOWS 45° (L 45)	SIZE (INCH)	a (mm.)	b (mm.)	c	PCS/ INNER	QTY OF INNER	PCS/ MASTER	WT/ MASTER KGS.
	1/8	17.0			50	B12	600	18
	1/4	18.5			30	B12	360	19
	3/8	20.3			50	12	600	42
	1/2	22.4			50	8	400	40
	3/4	24.9			40	6	240	38
	1	28.5			20	6	120	31
	1-1/4	32.8			20	4	80	30
	1-1/2	36.3			10	6	60	30
	2	42.7			12	3	36	26
	2-1/2	49.5			9	3	27	36
	3	55.1			10	2	20	33
	4	66.3			6	6	19	6
	5	77.5			6	6	23	6
	6	87.9			2	2	13	6



FIG. 240 RED. COUPLING (RED. SOCKETS) (RS)	SIZE (INCH)	a (mm.)	b (mm.)	c	PCS/ INNER	QTY OF INNER	PCS/ MASTER	WT/ MASTER KGS.
	1/4x1/8	28.8			30	B12	600	23
	3/8x1/8	28.7			35	B12	420	21
	3/8x1/4	28.7			30	B12	360	19
	1/2x1/8	31.8			50	12	600	38
	1/2x1/4	31.8			50	12	600	44
	1/2x3/8	31.8			40	12	480	36
	3/4x1/8	36.6			35	12	420	45
	3/4x1/4	36.6			30	12	360	36
	3/4x3/8	36.6			30	12	360	42
	3/4x1/2	36.6			60	6	360	43
	1x1/4	42.9			45	6	270	38
	1x3/8	42.9			30	6	240	36
	1x1/2	42.9			30	6	240	40
	1x3/4	42.9			25	6	200	38
	1-1/4x3/8	52.3			30	8	240	53
	1-1/4x1/2	52.3			25	6	150	37
	1-1/4x3/4	52.3			30	6	240	40
	1-1/4x1	52.3			15	8	120	34
	1-1/2x3/8	54.0			20	6	120	28
	1-1/2x1/2	54.0			20	6	120	28

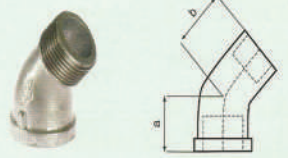

FIG. 121 STREET ELBOWS 45° (SL 45)	SIZE (INCH)	a (mm.)	b (mm.)	c	PCS/ INNER	QTY OF INNER	PCS/ MASTER	WT/ MASTER KGS.
	1/8	17.0	21.0		70	B12	840	23
	1/4	18.5	23.9		40	B12	480	22
	3/8	20.3	26.2		50	12	600	42
	1/2	22.4	29.2		75	6	450	38
	3/4	24.9	32.8		40	6	240	36
	1	28.5	37.3		25	6	150	33
	1-1/4	32.8	43.4		10	6	60	27
	1-1/2	36.3	47.8		10	6	60	28
	2	42.7	56.4		12	3	36	27
	2-1/2	49.5	65.3		12	2	24	32
	3	55.1	76.2		9	2	18	36
	4	66.3	94.0		7	2	14	25



FIG. 241 BUSHINGS (BU)	SIZE (INCH)	a (mm.)	b (mm.)	c	PCS/ INNER	QTY OF INNER	PCS/ MASTER	WT/ MASTER KGS.
	1/4x1/8	18.0		23.0	120	B12	1,440	28
	3/8x1/8	18.0		26.0	75	B12	900	19
	3/8x1/4	18.0		26.0	75	B12	900	17
	1/2x1/8	22.0		31.0	100	12	1,200	51
	1/2x1/4	22.0		31.0	100	12	1,200	47
	1/2x3/8	22.0		31.0	100	12	1,200	47
	3/4x1/8	24.0		33.0	50	12	600	44
	3/4x1/4	24.0		33.0	50	12	600	43
	3/4x3/8	24.0		33.0	50	12	600	38
	3/4x1/2	24.0		33.0	50	12	600	35
	1x1/8	19.2	29.8	28.9	50	8	400	48
	1x1/4	19.2	29.8	28.9	50	8	400	48
	1x3/8	19.2	29.8	28.9	50	8	400	48
	1x1/2	25.5	40.0	50	8	400	41	
	1x3/4	25.5	40.0	50	8	400	34	
	1-1/4x1/8	20.3	32.9	28.5	30	8	240	37
	1-1/4x1/4	20.3	32.9	28.5	30	8	240	41
	1-1/4x3/8	20.3	32.9	28.5	30	8	240	37
	1-1/4x1/2	20.3	32.9	34.0	30	8	240	48
	1-1/4x3/4	20.0	45.0	38	8	240	41	
	1-1/4x1	28.0	45.0	38	8	240	34	
	1-1/2x1/4	17.2	30.2	29.7	25	6	150	38
	1-1/2x3/8	17.2	30.2	29.7	25	6	150	38
	1-1/2x1/2	21.0	30.2	30.0	25	6	150	42
	1-1/2x3/4	21.0	35.4	41.5	25	6	150	43

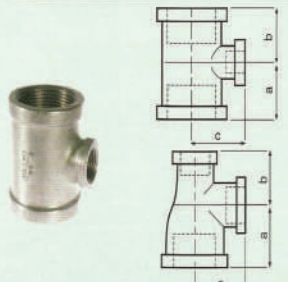

FIG. 130R RED. TEES (RT)	SIZE (INCH)	a (mm.)	b (mm.)	c	PCS/ INNER	QTY OF INNER	PCS/ MASTER	WT/ MASTER KGS.
	1/4x1/8	18.8	18.8	19.3	25	12	300	19
	3/8x1/8	20.6	20.6	21.6	40	12	480	37
	3/8x1/4	22.4	22.4	22.9	40	12	480	44
	1/2x1/8	22.8	22.8	23.8	30	12	360	40
	1/2x1/4	24.6	24.6	24.9	25	12	300	34
	1/2x3/8	26.4	26.4	26.2	45	6	270	39
	3/4x1/8	24.8	24.8	26.8	30	8	240	39
	3/4x1/4	26.7	26.7	27.4	25	8	200	36
	3/4x3/8	28.5	28.5	28.7	30	6	180	34
	3/4x1/2	30.5	30.5	31.0	30	6	180	36
	1x1/4	28.2	28.2	31.0	25	6	150	41
	1x3/8	30.0	30.0	32.3	20	6	120	33
	1x1/2	32.0	32.0	35.5	15	8	120	36
	1x3/4	34.8	34.8	36.8	25	4	100	33
	1-1/4x3/8	32.0	32.0	36.6				



FIG. 246 EXTENSION PIECES (X)	SIZE (INCH)	a (mm.)	b (mm.)	c	PCS/ INNER	QTY OF INNER	PCS/ MASTER	WT/ MASTER KGS.
	3/8	32.0			40	B12	480	22
	1/2	41.0			30	12	360	55
	3/4	48.1			40	6	240	62
	1	56.0			30	6	180	30
	1-1/4	90.0			30	4	120	30
	1-1/2	85.0			20	4	80	31
	2	71.0			15	4	60	36



FIG. 270
----------

# OS & Y Gate Valves

## Gate Valves

Ductile Iron Gate Valve to AWWA C509 Rising Stem, Resilient Wedge, 250 PSI Working Pressure, Flanged to ANSI B16.1 Class 125, Fusion Bonded Epoxy Coated to Fire Engine Red. Pre Grooved stem for supervisory switch mounting.

### Pressure

Working cold non-shock pressure : 250 PSI  
Hydrostatic test pressure Shell : 500 PSI,  
Seat : 250 PSI

### Application

Cold water, Fire water

### Options (Available on Request)

Bronze Stem  
BS 10 Table E Flange Drilling

### Accessories

Supervisory Switch, Model OSYSU-1,2

### Operation

Hand Wheel

### Ordering Information

Figure Number  
Flange Drilling  
Size ( 2 1/2" - 12")  
Stem ( SS / Brass )



### Material Specification

No	Component	Material
01	Body	Ductile Iron ASTM A536 Gr.65-45-12
02	Wedge	Ductile Iron ASTM A536 Gr.65-45-12, EPDM Encapsulated
03	Wedge Nut	Bronze ASTM B62 C83600
04	Gasket	EPDM
05	Stem	Brass ASTM B16 C36000 Stainless Steel AISI 304
06	Bonnet	Ductile Iron ASTM A536 Gr.65-45-12
07	O-Ring	EPDM
08	Washer	PTFE
09	Packing	Sq. Braided Non-Asbestos
10	Hand Wheel	Ductile Iron ASTM A536 Gr.65-45-12
11	Bolts and Nuts	Stainless Steel
12	Packing Gland	Ductile Iron ASTM A536 Gr.65-45-12
13	Yoke Nut	Bronze ASTM B62 C83600
14	Lock Nut	Ductile Iron ASTM A536 Gr.65-45-12, Chrome Plated

### Dimensions & Weights

Nominal Size DN (Inches)	A mm	B (Open / Close) mm	C mm	D mm	Weight Kg
2 1/2	190.5	408 / 350	184	178	26
3	203	485 / 414	254	190.5	31
4	229	605 / 491	254	228.6	47
6	267	790 / 628	305	279.4	78
8	292	1002 / 776	355.5	343	110
10	330	1187 / 933	444.5	406.4	195
12	356	1422 / 1110	444.5	483	310

Note: Sizes 4", 6" & 8" are FM approved



### ECON Cast Iron Gate Valve

#### Fig. GVOSY E 250

Resilient Wedge OS&Y

250 PSI / 16 bar

UL Listed

FM Approved

AWWA C509

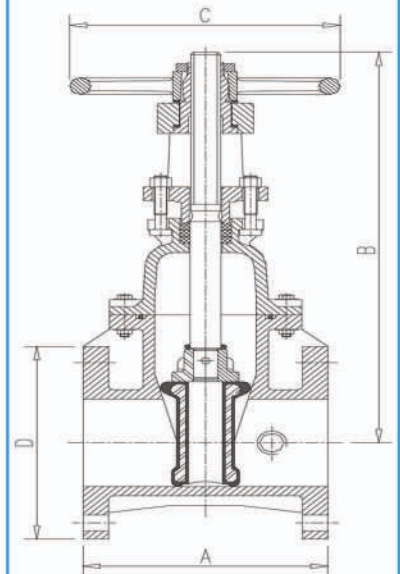



## NRS Gate Valves

### NRS Gate Valves

Ductile Iron Gate Valve to AWWA C515, Resilient Wedge, 300 PSI Working Pressure, Flanged to ANSI B16.1 Class 250, Fusion Bonded Epoxy Coated to Fire Engine Red.

#### Pressure

Working cold non-shock pressure : 300 PSI  
Hydrostatic test pressure Shell : 600 PSI  
Seat : 300 PSI

#### Application

Cold water, Fire water

#### Options (Available on Request)

EN 1092 - 2 PN 10 / PN16 Flange Drilling

#### Operations

Operating Nut  
Extension Spindles and T Keys  
Indicator Post

#### Ordering Information

Figure Number  
Flange Drilling  
Size ( 2 1/2" - 12")



ECON Ductile Iron Gate Valve

**Fig . GVNRS E 300 F**  
Resilient Wedge NRS  
300 PSI  
UL Listed  
FM Approved  
AWWA C515



#### Material Specification

No	Component	Material
01	Body	Ductile Iron ASTM A536 Gr.65-45-12
02	Wedge	Ductile Iron ASTM A536 Gr.65-45-12, EPDM Coated
03	Disc Nut	Bronze ASTM B62 C83600
04	Gasket	EPDM
05	Stem	Stainless Steel AISI 420
06	Bonnet	Ductile Iron ASTM A536 Gr.65-45-12
07	NPT Plug	Brass B16 C36000
08	Thrust Collar	Bronze ASTM B62 C83600
09	Gland	Ductile Iron ASTM A536 Gr.65-45-12
10	Wrench Nut	Ductile Iron ASTM A536 Gr.65-45-12
11	Post Plate	Ductile Iron ASTM A536 Gr.65-45-12

#### Dimensions & Weights

Nominal Size	L	D	H	Weight
DN (Inches)	mm	mm	mm	Kg
4	229	305	305	55
5	254	305	380	75
6	267	305	417	81
8	292	305	525	115
10	356	305	621	186
12	356	305	711	290

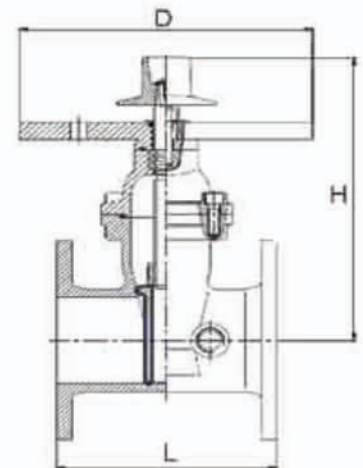

# Grooved Check Valves

## Check Valves

Ductile Iron swing Check valve, Maximum operating pressure - 300 PSI, Grooved ends, epoxy coated interior and exterior to fire engine red.

### Pressure

Working cold non-shock pressure: 300 PSI  
Max test pressure: 560 PSI

### Application

Cold water, Fire water

### Ordering Information

Valve Size ( 2" - 8")



### Material Specification

No	Component	Material
01	Body	Ductile iron conforming to ASTM A 536 epoxy coated
02	Clapper	2"-5" type 304 or 302 SS to ASTM A 167 6"-8" DI to ASTM A 536 65-45-12
03	Clapper Facing	EPDM Grade E /-40° to 230 F (-40° to 110 ) Service
04	Seat Ring	Type SS 304 to ASTM A-123 ASTM A-213, ASTM A-312 or ASTM A-269
05	Spring	Type 302 stainless steel to ASTM A-313
06	Hinge Pin	Type 304 or 302 stainless steel to ASTM A-580
07	Hinge Pin Bushings	Sintered bronze to ASTM B438

### Dimensions & Weights

Nominal Size	A	B	C	D	E	Weight
DN (Inches)	mm	mm	mm	mm	mm	Kg
2	169	60	36	81	111	2.5
2.5	183	61	39	86	114	5.0
3	198	67	51	93	125	6.0
4	218	79	57	108	152	9.0
6	270	108	84	171	216	18.0
8	325	128	100	203	260	33.0

### Strainers

#### General Design & Application:

Solid contamination is detrimental to the performance and life of fluid transfer systems. It is therefore extremely important to remove solid contamination from fluid transfer systems. This will protect the pipeline and all the associated equipment / instruments on the line which are mostly sensitive to dirt. Corrosion deposits, scaling, welding slag, sealing compounds as well as several other materials are trapped and prevented from causing system contamination and subsequent problems and failures.

The ECON fire service 'Y' type strainer design offers a reliable and cost effective means of equipment protection, minimizing downtime and maintenance costs. The design of ECON strainers is supported by the decades of experience in the field of fluid handling. Straining is a process of directly intercepting solid particles when the fluid passes through the strainer element / perforated screen. The strainer screen perforations / mesh size are small enough to prevent passage of solid contamination / dirt to the downstream.

The ECON bronze strainers have a strong stainless steel wire mesh screen / element insert. All iron y type strainers are listed with UL for use in fire protection systems. For mesh screen holes sizes please refer the data sheets. The pressure drop through the ECON strainers is minimized due to its streamlined flow design. The strainers have a compact design.

Note: It is extremely important that the Strainer screen is cleaned at frequent intervals in order to avoid damage to screens / elements due to choking (dirt build-up). This will also help to get a better life from the Strainer screen / element. We strongly advise that the strainer screens should be cleaned at regular intervals especially during initial flushing and start up.

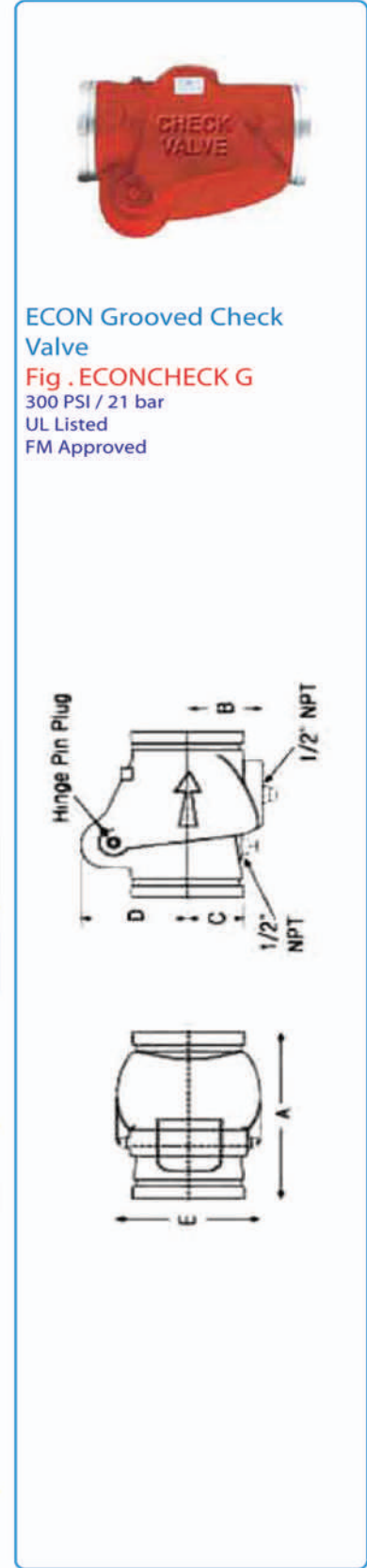

ECON Grooved Check Valve

Fig . ECONCHECK G

300 PSI / 21 bar

UL Listed

FM Approved

# Alarm Check Valves

## Alarm Check Valves

### General Design & Application:

The model ACV F 175 Alarm Check Valve is designed for installation in wet pipe sprinkler systems as per NFPA 13 requirements. The valve is a double seated clapper swing check valve with a grooved seat design, which ensures positive water flow for alarm operation. The model ACV F 175 valve serves as a check valve and also generates an alarm when a sprinkler has operated by operating a water motor alarm and /or a pressure switch. When installed with a water- motor alarm the system can provide a local alarm even in the event of power supply failure. The Model ACV F 75 alarm check valve can be used in systems with a variable pressure water supply by adding the retard chamber to the constant pressure trim. The Econ Alarm check valve complete with trim is listed by UL for use in wet pipe sprinkler system.



Alarm Check Valve assembly complete with constant pressure trim, retard chamber and water motor alarm gong

Cast Iron Check valve, Maximum operating pressure - 12 bar, Flanged ends to ANSI B16.1 Class 125 FF, Threaded tapping BSPT, suitable for vertical mounting, Fire Engine Red Epoxy painting.

**Pressure**  
Working cold non-shock pressure : 175 PSI  
Hydrostatic test pressure : 355 PSI

**Application**  
Wet pipe system as per NFPA 13 and NFPA 25

**Options (Available on Request)**  
Flange drilling to IS : 1538  
NPT Threaded opening

**Accessories**  
Constant Pressure trim  
Retard Chamber  
Water Motor Alarm gong

**Ordering Information**  
Valve Size (3" - 8")  
Flange Drilling  
Trim Details

### Material Specification

No	Component	Material
01	Housing	Cast Iron
02	Seat	Bronze
03	Clapper	Bronze
04	Seat Rubber	Neoprene
05	Rubber Clamp	Stainless Steel AISI 304
06	Bolt	Stainless Steel AISI 304
07	Clapper Bush	Bronze
08	Body Bush	Bronze
09	Hinge Pin	Stainless Steel AISI 304
10	Bolts	Steel
11	Plug	Brass
12	Cover Gasket	Neoprene
13	Hand hold Cover	Cast Iron

### Dimensions & Weights

Nominal Size	A	B	C	Weight (w/o Trim)
DN (Inches)	mm	mm	mm	Kg
3	325	114	115	28
4	350	140	129	36
6	382	170	154	52
8	423	180	171	86



ECON Cast Iron Alarm Check Valve

Fig . ACV F 175  
175 PSI / 12 bar  
UL Listed

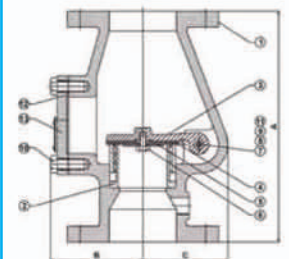

## Grooved Butterfly Valves & Y Strainer

### Grooved Butterfly Valves

Ductile Iron Butterfly valves, Grooved Ends, 300 PSI operating pressure EPDM encapsulated Disc, Gear operated, C/W with factory installed dual tamper switches.

#### Pressure

Working cold non-shock pressure : 300 PSI

#### Application

Cold water, Fire water

#### Ordering Information

Figure Number  
Size ( 2 1/2" - 8")



#### Material Specification

No	Component	Material
01	Body	Ductile Iron ASTM A536 Nylon Coated
02	Disc	Ductile Iron ASTM A536 EPDM Encapsulated
03	Stems	Stainless Steel AISI 420
04	Worm Gear Shift	Stainless Steel AISI 420
05	Gear housing	Ductile Iron ASTM A536 65-45-12
06	Hand Wheel	Ductile Iron ASTM A536 65-45-12
07	Segment Gear	Bronze ASTM B-148/ASTM B584
08	Gasket & "O" Ring	EPDM Grand "E"

#### Dimensions & Weights

Nominal Size DN (Inches)	A mm	B mm	C mm	D mm	E mm	F mm	G mm	H mm	Weight Kg
2.5	105	85	96.4	73	135	128	128	-	9.0
3	122	92	96.4	88.9	142	128	128	-	9.5
4	145	108	115.4	114.3	175	128	128	-	11.5
6	179	145	132.4	168.3	209	220	220	6.8	17.5
8	204	170	147.4	219.1	234	220	220	24.2	23



ECON Grooved Butterfly Valves

Fig . HPG  
300 PSI / 21 bar  
UL Listed  
FM Approved

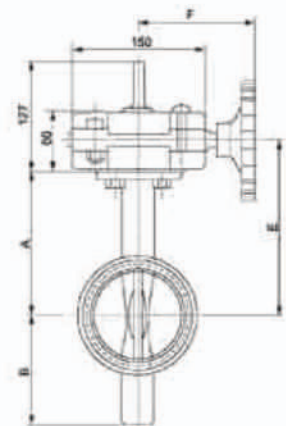

### Y Strainers

Cast Iron Y strainer, 175 PSI operating pressure, Flanged Ends to ANSI B16.1 Class 125, Epoxy Coated to Fire Engine Red.

#### Pressure

Working cold non-shock pressure : 175 PSI

#### Application

Cold water, Fire water

#### Ordering Information

Figure Number  
Size ( 2 1/2" - 12")



#### Material Specification

No	Component	Material
01	Body	Cast Iron ASTM A126 Class B
02	Cover	Cast Iron ASTM A126 Class B
03	Screen	Stainless Steel AISI 304
04	Gasket	PTFE/Graphite
05	Plug	Ductile Iron ASTM A536 Gr. 65-45-12

#### Dimensions & Weights

Nominal Size DN (Inches)	A mm	B mm	C Inches	Weight Kg
2.5	273	135	1	14
3	295	215	1	17.3
4	352	245	1	32
5	416	295	1	47.5
6	470	320	1 1/2	62.5
8	543	415	1 1/2	107.5
10	660	485	2	175.5
12	770	560	2	253.0



ECON Cast Iron Y Strainer

Fig . YS-F-1161 EF  
175 PSI / 12 bar  
UL Listed

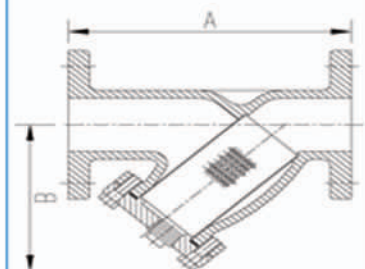

# Breaching Inlet & Landing Values & Fire Hydrant

## 2 Way & 4 Way Breaching Inlet

### WET & DRY RISER EQUIPMENT

Kolling 2 way and 4 way Inlet Breaching are manufactured to BS 5041: Pt. 3. Landing valve boxes for dry risers are manufactured to BS 5041 Pt. 4. Foam inlet and dry riser boxes are manufactured to BS 5041: Pt. 5.

#### GENERAL SPECIFICATIONS

Two way & Four way Inlet Breaching

Body Material	: Spheroidal Graphite Iron to BS 2789
Inlet	: 65mm Male Instantaneous to BS 336, Copper Alloy to BS 1400
Outlet – 2 Way Breaching	: 100mm PN16 to BS4504/4" ANSI Class 150 F.F
4 Way Breaching	: 150mm PN16 to BS 4504/6" ANSI Class 150 F.F
Working Pressure	: 10 Bar (145 psi)
Test Pressure	: 20 bar (290 psi)



DC 707-S



DC 708

## Landing Valve

### OBLIQUE VALVE



Code	Inlet Size	Outlet
HV005	2 1/2" (65mm) BSPT Male	2 1/2" Female
HV005(F)	2 1/2" (65mm) PN16 to BS4504	inst. to BS 336

### RIGHT ANGLE VALVE



Code	Inlet Size	Outlet
HV003	2 1/2" (65mm) BSPT Male	2 1/2" Female
HV003(F)	2 1/2" (65mm) PN16 to BS4504	inst. to BS 336

## Fire Hydrant



PH 1001



PH 1002



SPP 9522B5

16

### Fire Hydrant

Kolling manufactures Pedestal Hydrant consist of High and Low Pressure Type. Kolling hydrants are suitable for use in refineries, factories and public housing.

#### General Specification (High Pressure)

Body Material	: Carbon Steel
Outlet	: HV007
Test Pressure	: 30 bar (435 psi)
Working Pressure	: 20 bar (290 psi)
Seat Test Pressure	: 22 bar (319 psi)
Finishing	: Red

#### General Specification (Low Pressure)

Body Material	: Cast Iron to BS1452
Outlet	: HV005
Test Pressure	: 22.5 bar (326 psi)
Working Pressure	: 15 bar (217 psi)
Seat Test Pressure	: 16.5 bar (239 psi)
Finishing	: Red

Other inlet and outlet connection are available upon customer requirement.

#### 2 WAY FIRE HYDRANT

Code	Outlet	Inlet	Body	Type
PH 1001	2 x 65mm Male Thread	100mm PN 16 To BS 4504	Cast Iron	Low Pressure
PH 1002	2 x 65mm Hydrant Valve with Female Instantaneous BS 336	100mm PN 16 To BS 4504	Cast Iron	Low Pressure
SPP 9513	2 x 65mm Self regulating Valve with Female Instantaneous BS 336	100mm ANSI 150 FF	Carbon Steel	High Pressure
SPP 9522NH	2 x 65mm Self Regulating Valve with Male NHT	100mm ANSI 150 FF	Cast Iron	Low Pressure
SPP 9522B5	2 x 65mm Self Regulating Valve Female Instantaneous BS 336	100mm PN 16 To BS 4504	Cast Iron	Low Pressure

#### 3 WAY FIRE HYDRANT

Code	Outlet	Inlet	Body	Type
SPP 9527	2 x 65mm Hydrant Valve/ Self Regulating Valve (SRT) with Male NHT. 1 x 100mm Male NHT (Pumper). 1 x 100mm ANSI Class 150 FF Flange (Monitor Mounting).	150mm ANSI Class 150 FF Flange	Cast Iron	High Pressure

Code	Outlet	Inlet	Body	Type
PH 1003 (A)	2 x 65mm Male Thread 1 x 100mm Female Round Thread BS 336 (Pumper)	150mm PN 16 To BS 4504	Cast Iron	Low Pressure
PH 1003 (B)	2 x 65mm Hydrant Valve with Female Instantaneous BS 336 1 x 100mm Female Round Thread BS 336 (Pumper)	150mm PN 16 To BS 4504	Cast Iron	Low Pressure
SPP 9526	2 x 65mm Self Regulating Valve with Female Instantaneous BS 336 1 x 100mm Female Round Thread BS 336 (Pumper)	150mm PN 16 To BS 4504	Cast Iron	Low Pressure

#### UNDERGROUND HYDRANT

##### General Specification (Low Pressure)

Body	: Cast Iron to BS1452
Outlet	: Copper Alloy to BS1400 Round / V-Thread
Inlet	: 75mm Flange to PN16
Test Pressure	: 20 bar (300 psi)
Code	: PH1004



SPP 9527



PH 1003 (A)



PH 1003 (B)

17

# Fire Fighting Fittings

## Fire Hose Reels & Fire Hose Reels Cabinets

### Fire Cabinet Single Doors

### Fire Cabinet Double Doors



#### SINGLE DOOR CABINETS

In Variety of Sheets

Standard Dimension 800 (W) x 800 (H) x 300 (D) mm

Type	Thickness	Material	Equipment inside the Cabinet	Finish
Recessed	1.2 mm	Mild Steel/GI	Fire Hose Reel or	Red Powder Coated
Surface Mounted		Mild Steel/GI / Stainless Steel	Fire Hose & Branch Pipe or	Red Powder Coated or Stainless Steel
Semi Recessed	1.2 mm	Stainless Steel Brush/Mirror Finish	Landing Valve	Red Powder Coated with Stainless Steel
Self Standing		Mild Steel/GI	Hose Rack	Red Powder Coated

#### BREACHING INLET CABINETS

In Variety of Sheets

Standard Dimension 600 (W) x 400 (H) x 300 (D) mm (2 WAY)  
 Standard Dimension 600 (W) x 600 (H) x 300 (D) mm (4 WAY)

Type	Thickness	Material	Equipment inside the Cabinet	Finish
Recessed	1.2 mm	Mild Steel/GI with Glass	2 Way Breaching Inlet or	Red Powder Coated
Surface Mounted		Mild Steel/GI with Glass	4 Way Breaching Inlet	Red Powder Coated
Semi Recessed	1.2 mm	Stainless Steel Brush/Mirror Finish with Glass		Red Powder Coated with Stainless Steel
Self Standing		Mild Steel/GI		Red Powder Coated

• Thickness of cabinets can be changed upon clients request.

#### DOUBLE DOOR CABINET FOR FIRE HOSE REEL, LANDING VALVE & FIRE EXTINGUISHER

STANDARD TECHNICAL SPECIFICATION

Dimension	800 (W) x 1600 (H) x 300 (D) mm
Material	Stainless Steel / Mild Steel / GI
Thickness	1.2 mm
Installation	Surface type, Recessed type, Semi Recessed type
Capacity	Manual or Automatic swing, Fixed Hose Reel 3/4" or 1" & Landing Valve
Paint Finish	Red Powder Coated, Mirror Finish, Brush Finish
Hinges	Push Pin, Plano Hinges Stainless Steel
Door Handle	Chrome plated or Stainless Steel

• Thickness of cabinets can be changed upon clients request.

## Fire Hose Real



#### Specification

Diameter	mm	38	45	50	63	70	76	102	127	152
	Inches	1½	1¾	2	2½	2¾	3	4	5	6
Burst Pressure (min.)	kgf/cm <sup>2</sup>	50	50	50	50	50	42	38	38	38
Proof Pressure	kgf/cm <sup>2</sup>	25	25	25	25	25	21	19	19	19
Kink Test Pressure	kgf/cm <sup>2</sup>	25	25	25	25	25	21	19	19	19
Working Pressure	kgf/cm <sup>2</sup>	14	17	17	17	17	15	15	15	15
30 m. Length Coil Dia.	cm	45	55	55	55	55	60	60	60	60
Mass per Meter (Max.)	gm	275	370	425	500	600	650	950	950	950
Abrasion Resistance (Min.) (at 7 kg/cm <sup>2</sup> Pressure)	Cycles	100	200	200	200	200	200	200	200	200
Heat Resistance	Sec. (Min.)	8	20	20	20	20	20	20	20	20

# Fire Fighting Fittings

## Fire Extinguishers & Blanket

### 3 KG ABC POWDER

#### Description

MODEL	FABC3
Classification	ABC
KM No.	577694
Fire Rating	21A/70B
Extinguisher Agent	40%ABC Powder
Hydrostatic Test Pressure	30 Bar
Operating pressure	15 Bar
Propellant	Dry Nitrogen
Max.Temp. Range	-30°C To +60°C
Agent mass	3 Kg.
Total Mass	4.96 Kg.
Discharge Time	21 sec.



### 2 KG CARBON DIOXIDE

#### Description

MODEL	FCO22
Classification	BC
KM No.	577694
Fire Rating	34B
Extinguisher Agent	CO <sub>2</sub>
Hydrostatic Test Pressure	250 Bar
Operating pressure	70 Bar
Propellant	CO <sub>2</sub>
Max.Temp. Range	-30°C To +60°C
Agent mass	2 Kg.
Total Mass	6.24 Kg.
Discharge Time	20 sec.



### 4 KG ABC POWDER

#### Description

MODEL	FABC4
Classification	ABC
KM No.	577694
Fire Rating	27A/113B
Extinguisher Agent	40%ABC Powder
Hydrostatic Test Pressure	30 Bar
Operating pressure	15 Bar
Propellant	Dry Nitrogen
Max.Temp. Range	-30°C To +60°C
Agent mass	4 Kg.
Total Mass	6.3 Kg.
Discharge Time	23 sec.



### 5 KG CARBON DIOXIDE

#### Description

MODEL	FCO25
Classification	BC
KM No.	577694
Fire Rating	89B
Extinguisher Agent	CO <sub>2</sub>
Hydrostatic Test Pressure	250 Bar
Operating pressure	70 Bar
Propellant	CO <sub>2</sub>
Max.Temp. Range	-30°C To +60°C
Agent mass	5 Kg.
Total Mass	13.38 Kg.
Discharge Time	27 sec.



#### Application

Mainly equipped for the kitchen, to put out fire caused by over heated oil in cooking, also can be equipped in the cars and ships, warehouses and oil stations etc. Can effectively put out small fires and can be wrapped around bodies on fire, save people and help escape in time.

#### Specialities

Excellent fire proof, heat resistance and insulation properties, effectively eliminates air and absorbs heat to suppress fire immediately.



#### Sizes Available:

MODEL NO.	SIZE
FB4	1.2M X 1.2M
FB6	1.2M X 1.8M
FB0606 (NON LPCB)	1.8M X 1.8M

#### HOW TO USE

1. Pull tabs downwards to release.
2. Cover burning material completely.
3. Switch off heat and leave covered until cool.



# Fire Fighting Fittings

## Fire Sprinkler Systems



### AUTOMATIC SPRINKLERS GL SERIES UPRIGHT • PENDENT VERTICAL SIDEWALL HORIZONTAL SIDEWALL CONVENTIONAL (OLD STYLE)

#### DESCRIPTION AND OPERATION

The Globe GL Series Sprinkler is a low profile yet durable design which utilizes a frangible glass ampule as the thermo-sensitive element. While the sprinkler provides an aesthetically pleasing appearance, it can be installed wherever standard spray sprinklers are specified. This sprinkler series is available in various styles, orifices, temperature ratings and finishes to meet varying design requirements.

The heart of Globe's GL Series sprinkler proven actuating assembly is a hermetically sealed frangible glass ampule that contains a precisely measured amount of fluid. When heat is absorbed, the liquid within the bulb expands increasing the internal pressure. At the prescribed temperature the internal pressure within the ampule exceeds the strength of the glass causing the glass to shatter. This results in water discharge which is distributed in an approved pattern depending upon the deflector style used.

#### TECHNICAL DATA

- See reverse side for Approvals and Specifications.
- Temperature Ratings - 135°F (57°C), 155°F (68°C), 175°F (79°C), 200°F (93°C), 286°F (141°C), 360°F (182°C)
- 500°F (260°C) Available Upon Request Without Approvals
- Water Working Pressure Rating - 175 psi (12 Bars)
- Factory tested hydrostatically to 500 psi (34 Bars)
- Maximum low temperature glass bulb rating is -67°F (-55°C)
- Frame - bronze • Deflector - brass • Screw - brass
- Bulb seat - copper • Spring - nickel alloy • Seal - teflon
- Bulb - glass with glycerin solution, 5mm size



UPRIGHT



CONVENTIONAL



PENDENT



VERTICAL SIDEWALL



HORIZONTAL SIDEWALL



#### • SPRINKLER TEMPERATURE RATING/CLASSIFICATION and COLOR CODING

CLASSIFICATION	AVAILABLE SPRINKLER TEMPERATURES		BULB COLOR	N.F.P.A. MAXIMUM CEILING TEMPERATURE	
ORDINARY	135°F/155°F	57°C/68°C	ORANGE/RED	100°F	38°C
INTERMEDIATE	175°F/200°F	79°C/93°C	YELLOW/GREEN	150°F	66°C
HIGH	286°F	141°C	BLUE	225°F	107°C
EXTRA HIGH	360°F	182°C	MAUVE	300°F	149°C
ULTRA HIGH	500°F	260°C	BLACK	475°F	246°C

4077 AIRPARK DRIVE, STANDISH, MICHIGAN 48658

989-846-4583 • FAX 989-846-9231

MARCH 2011

A-65

BULLETIN GL5661, REV. #4



# Fire Fighting Fittings

## Fire Sprinkler Systems

### HK Series Automatic Sprinklers



#### Overview:

ISST sprinkler is widely used in high rise building, warehouses, hotels, and underground projects. It has advantages of good structure, stable performance, safety, reliability, high corrosion resistance and long usage life. Besides, it can be concealed in ceiling with decoration paint for elegant look.

#### Features:

- UL Listed
- Nominal 5.6 K - Factor
- Corrosion resistant coating for long life.

#### Product Information

MODEL	DESCRIPTION
HKxxx	Automatic Sprinklers

#### Technical Specifications:

Model	Response	Type	System Working Pressure	Temp Rating °C
HK001	SR	Upright	175	68 °C / 79 °C / 93 °C
HK002	QR	Upright	175	68 °C / 79 °C / 93 °C
HK003	SR	Pendent	175	68 °C / 79 °C / 93 °C
HK004	QR	Pendent	175	68 °C / 79 °C / 93 °C
HK003	SR	Upright	175	57°C / 68 °C / 79 °C / 93 °C
HK004	QR	Upright	175	57°C / 68 °C / 79 °C / 93 °C
HK005	SR	Pendent	175	57°C / 68 °C / 79 °C / 93 °C
HK006	QR	Pendent	175	57°C / 68 °C / 79 °C / 93 °C
HK005	SR	Side Wall Horizontal	175	68 °C / 79 °C / 93 °C
HK006	QR	Side Wall Horizontal	175	68 °C / 79 °C / 93 °C
HK017 * #	SR	Side Wall Horizontal	175	57°C / 68 °C / 79 °C / 93 °C
HK018 * #	QR	Side Wall Horizontal	175	57°C / 68 °C / 79 °C / 93 °C

\*- Installed 4 to 6 inch below ceiling

#- For ordinary hazard occupancies

## Fire Sprinkler Monitoring

- ❖ Water Flow Detector - Potter
- ❖ Water Pressure Switch - Potter
- ❖ Water Tamper Switch - Potter
- ❖ Pressure Gauge 300 PSI - Ashcroft
- ❖ Pressure Gauge 250 PSI - Econ
- ❖ Liquid Pressure Gauge 250 -300 PSI
- ❖ Sprinkler Alarm Gung



## Fire Rated Door

The Decorative fire doors are made of high quality materials  
It can be customized by clients requirements

These are made in a wide range of styles from a choice of materials colors and designs  
We supply the doors of our own UI Certified factory







**LOWARA** Water Pump  
a xylem brand

**VERTICAL TYPE-MULTI STAGE PUMP**

**A: e-SV Series sommerse elettropompe verticali**



**Specification**

- Portata: fino a 160 m<sup>3</sup>/h
- Prevalenza: fino a 330 m
- Alimentazione: mono e tri-fase 50 e 60 Hz
- Potenza: da 0,37 kW fino a 55 kW

**B-SVI Series sommerse elettropompe verticali**



**Specification**

- Portata: fino a 120 m<sup>3</sup>/h
- Prevalenza: fino a 240 m
- Alimentazione: 50 Hz
- Potenza: da 0,37 kW fino a 30 kW
- Pressione massima: 25 bar
- Temperatura del liquido da -10 °C a 90 °C

**C: VM Series sommerse elettropompe verticali**



**Specification**

- Delivery: up to 14 m<sup>3</sup>/h
- Head: up to 99 m
- Power supply: both 1 Ph & 3 Ph 50 and 60 Hz
- Power: from 0.30 kW up to 3 kW
- Maximum operating pressure: 10 bar
- Temperature of pumped liquid: from -10 °C to 90 °C

**D-TDB, TDV Series sommerse elettropompe verticali**



**Specification**

- Delivery: up to 340 m<sup>3</sup>/h
- Head: up to 500 m
- Power supply: three-phase 50 Hz
- Power: from 2.20 kW up to 355 kW
- Maximum operating pressure: 63 bar
- Temperature of pumped liquid: from -10 °C to 140 °C

**E: GHV Variable speed booster sets**



**Specification**

- Delivery: up to 640 m<sup>3</sup>/h
- Head: up to 160 m
- Power: up to 22 kW
- Maximum operating pressure: 16 bar

**B-eSV Series Variable speed booster sets**



**Specification**

- Delivery: up to 750 m<sup>3</sup>/h
- Head: up to 160 m
- Power: up to 37 kW
- Maximum operating pressure: 16 bar



**LOWARA** Water Pump  
a xylem brand

### HORIZONTAL TYPE

F: GXS20, GMD20, GTKS20, GHV20 Booster Set



#### Specification

- Delivery: up to 62 m<sup>3</sup>/h
- Head: up to 160 m
- Power: up to 4 kW
- Maximum operating pressure: 16 bar

D: FH Elettropompe centrifughe secondo  
EN 733 – DIN 24255



#### Specification

- Portata: fino a 700 m<sup>3</sup>/h
- Prevalenza: fino a 100 m
- Alimentazione: mono e tri-fase 50 e 60 Hz
- Potenza: da 0,25 kW fino a 132 kW
- Pressione massima: 16 bar
- Temperatura del liquido da -30 °C a 120 °C

E: e-HM Multi Stage Pump



#### Specification

- Portata: fino a 29 m<sup>3</sup>/h
- Prevalenza: fino a 160 m
- Alimentazione: mono e tri-fase 50 e 60 Hz
- Potenza: da 0,30 kW fino a 5,50 kW
- Pressione massima: 16 bar
- Temperatura del liquido da -10 °C a 120 °C

B: CO Filettate pompe centrifughe con girante aperta



#### Specification

- Portata: fino a 54 m<sup>3</sup>/h
- Prevalenza: fino a 24 m
- Alimentazione: mono e tri-fase 50 e 60 Hz
- Potenza: da 0,37 kW fino a 3 kW
- Pressione massima: 8 bar
- Temperatura del liquido da -10 °C a 120 °C

C: BG Elettropompe autoadescanti centrifughe



#### Specification

- Portata: fino a 4,20 m<sup>3</sup>/h
- Prevalenza: fino a 53 m
- Alimentazione: mono e tri-fase 50 e 60 Hz
- Potenza: da 0,37 kW fino a 1,10 kW
- Pressione massima: 8 bar
- Temperatura del liquido da -10 °C a 40 °C

### SUBMERSIBLE DRAINAGE & SEWAGE PUMP

DL Series



#### Specification

- Portata: fino a 42 m<sup>3</sup>/h
- Prevalenza: fino a 21 m
- Alimentazione: mono e tri-fase 50 e 60 Hz
- Potenza: da 0,60 kW fino a 1,50 kW
- Temperatura del liquido a 50 °C
- Massima profondità di immersione: 5 m
- Passaggio libero: fino a 50 mm

DOMO GRI



#### Specification

- Portata: fino a 6,60 m<sup>3</sup>/h
- Prevalenza: fino a 25 m
- Alimentazione: mono e tri-fase 50 e 60 Hz
- Potenza: da 1,10 kW fino a 1,10 kW
- Temperatura del liquido a 35 °C

GLS, GLV



#### Specification

- Power: up to 7.40 kW
- Residential-Wastewater
- Light Industry-Wastewater

DOC Series



#### Specification

- Portata: fino a 14 m<sup>3</sup>/h
- Prevalenza: fino a 11 m
- Alimentazione: mono e tri-fase 50 e 60 Hz
- Potenza: da 0,25 kW fino a 0,55 kW

SCUBA Elettropompe sommerse monoblocco



#### Specification

- Portata: fino a 7,50 m<sup>3</sup>/h
- Prevalenza: fino a 80 m
- Alimentazione: mono e tri-fase 50 e 60 Hz
- Potenza: da 0,55 kW fino a 1,10 kW
- Temperatura del liquido a 40 °C
- Massima profondità di immersione: 20 m
- Passaggio libero: fino a 2,5 mm

# LOWARA Water Pump

a xylem brand

## CIRCULATION PUMP

### TLCB, TLCHB Series



#### Specification

- Portata: fino a 12 m<sup>3</sup>/h
- Prevalenza: fino a 12 m
- Alimentazione: mono-fase 50 Hz
- Potenza: da 0,03 kW fino a 0,40 kW
- Pressione massima: 10 bar
- Temperatura del liquido da -10 °C a 65 °

### TLC, TLCH Series



#### Specification

- Portata: fino a 12 m<sup>3</sup>/h
- Prevalenza: fino a 12 m
- Alimentazione: mono-fase 50 Hz
- Potenza: da 0,03 kW fino a 0,40 kW
- Pressione massima: 10 bar
- Temperatura del liquido da -10 °C a 110 °C

### FC-FCT Series



#### Specification

- Portata: fino a 330 m<sup>3</sup>/h
- Prevalenza: fino a 89 m
- Alimentazione: mono e tri-fase 50 e 60 Hz
- Potenza: da 0,25 kW fino a 22 kW
- Pressione massima: 16 bar
- Temperatura del liquido da -20 °C a 140 °C

### FLC, EFLC Series



#### Specification

- Delivery: up to 80 m<sup>3</sup>/h
- Head: up to 20 m
- Power supply: both 1 Ph & 3 Ph 50 Hz
- Power: from 0.10 kW up to 2.50 kW
- Maximum operating pressure: 10 bar
- Temperature of pumped liquid: from -15 °C to 120 °C

## B: Water Heaters



### INSTANT HEATER

[view detail >](#)

Model	Ti-Shape 50VE	Ti-Shape 80VE	Ti-Shape 100VE	Ti-Shape 80HE	Ti-Shape 100HE
Kapasitas (liter)	50	80	100	80	100
Daya Listrik (watt)	1.200	1.200	1.500	1.200	1.500
Voltase (volt)	230	230	230	230	230
Instalasi	Vertikal			Horisontal	
Max. Temperatur (°C)	80°	80°	80°	80°	80°
Tekanan Maks. (Bars)	8	8	8	8	8
Ø Pipa inlet/outlet (Inch)	1/2	1/2	1/2	1/2	1/2
Ukuran (mm)	470x470x585	470x470x790	470x470x943	790x470x470	943x470x470
Berat bersih (Kg)	19.8	25.8	30.9	25.8	30.9
Pelindung terhadap korosi	Lapisan MTS Technology Titanium Enamel + Magnesium Anode				



# 4- WATER HEATERS



## MODEL NUMBERS

M-2-HE40S6DS	40 Capacity	Short
M-2-HE50S6DS	50 Gallon Capacity	Tall
M-2-HE65R6DS	65 Gallon Capacity	Standard
M-2-HE80R6DS	80 Gallon Capacity	Standard

### Features

- Direct heat transfer with immersion elements
- Fully automatic controls
- Factory installed Hydrojet® Total Performance System
- Factory installed dielectric waterway fittings
- Protective magnesium anode rod
- Vitraglas® lining
- Heat traps
- T&P relief valve opening
- Brass drain valve
- 2" Non-CFC foam insulation



## MODEL NUMBERS

M-2-30L6DS 30	Gallon Capacity	Lowboy
M-2-40L6DS 40	Gallon Capacity	Lowboy
M-1-50L6DS 47	Gallon Capacity	Lowboy

### Features

- Fully Automatic Controls
- Hydrojet® Total Performance System
- Direct Heat Transfer with Immersed Elements
- Optional Conversion Kits Available
- Lowboy Models Provided with Insulation Wrap
- Vitraglas® Lining
- Max Temp - 160°F
- ¾" NPT Dielectric Waterway Fittings
- Low Restriction Brass Drain Valve
- T&P Relief Valve Installed
- Protective Magnesium Anode Rod
- 1" Non-CFC Foam Insulation
- 6-Year Tank and Parts Warranty



## MODEL NUMBERS

M-1-10U6SS	10 Gallon Capacity	Utility
M-1-15U6SS	15 Gallon Capacity	Utility
M-1-20U6SS	19 Gallon Capacity	Utility
M-2-30U6SS	30 Gallon Capacity	Utility

### Features

- Direct heat transfer with immersed element
- Fully automatic controls
- Vitraglas® lining
- Factory installed dielectric waterway fittings
- Protective magnesium anode rod
- T&P relief valve opening
- 1" Non-CFC foam insulation



# Residential Electric Water Heaters

## ELECTRIC

### TALL AND SHORT MODELS AVAILABLE

#### DYNACLEAN™ DIFFUSER DIP TUBE

Helps reduce lime and sediment buildup, maximizes hot water output. Made from long-lasting PEX cross-linked polymer.

#### COREGARD™ ANODE ROD

A. O. Smith's exclusive anode has a stainless steel core, protects tank against corrosion.

#### DURABLE, TAMPER-RESISTANT BRASS DRAIN VALVE

#### PERMAGLAS® GLASS COATING

Protects steel tank from corrosion and maximizes tank life.

#### CSA CERTIFIED AND ASME RATED T&P RELIEF VALVE

#### CODES AND STANDARDS

Certain ProMax Electric models meet the requirements of the BC Energy Efficiency Act. See table on reverse for more details.

#### 8-YEAR LIMITED TANK AND 6-YEAR PARTS WARRANTY

For complete information, consult written warranty or A. O. Smith Water Products Company.



### CAPACITY & DIMENSIONS

MODEL NUMBER	SERIES	CAPACITY GALLON	ELEMENT WATTAGE		FIRST HOUR RATING GALLONS	STANDBY LOSS WATTS	DIMENSIONS IN INCHES		APPROX. SHIPPING WEIGHT (LBS.)	BC COMPLIANT
			WATTS	VOLTS			(A) HEIGHT	(B) DIAMETER		
<b>TOP ENTRY</b>										
EPSX 50	200	50	3000	208	60	57	48-3/4	22	129	√
EPSX 50	200	50	3000	240	60	57	48-3/4	22	129	√
ECS 50	210	50	3000	208	60	66	48	21-1/2	116	-
ECS 50	210	50	3000	240	60	66	48	21-1/2	116	-
ECS 50	210	50	3800	240	60	66	48	21-1/2	116	-
EPSX 50	200	50	4500	208	60	57	48-3/4	22	129	√
EPSX 50	200	50	4500	240	60	57	48-3/4	22	129	√
ECS 50	210	50	4500	208	60	66	48	21-1/2	116	-
ECS 50	210	50	4500	240	60	66	48	21-1/2	116	-
EPSX 50	200	50	6000	208	60	57	48-3/4	22	129	√
EPSX 50	200	50	6000	240	60	57	48-3/4	22	129	√
ECS 50	210	50	6000	208	60	66	48	21-1/2	116	-
ECS 50	210	50	6000	240	60	66	48	21-1/2	116	-
ECT 80	200	80	3000	208	81	78	60-1/2	24	180	√
ECT 80	200	80	3000	240	81	78	60-1/2	24	180	√
ECT 80	200	80	3800	240	81	78	60-1/2	24	180	√
ECT 80	200	80	4500	208	81	78	60-1/2	24	180	√
ECT 80	200	80	4500	240	81	78	60-1/2	24	180	√
ECT 80	200	80	6000	208	81	78	60-1/2	24	180	√
ECT 80	200	80	6000	240	81	78	60-1/2	24	180	√
<b>BOTTOM ENTRY</b>										
EJSH 50	100	50	3000	240	60	66	48	22	123	√
EJSH 50	100	50	4500	208	60	66	48	22	123	√
EJTH 80	100	80	4500	208	81	82	60-1/2	24	208	√
EJTH 80	100	80	4500	240	81	82	60-1/2	24	208	√

**ProMax®** ELECTRIC



# 5- WATER FILTERERS

**Pentair**  
Water Filter



Clack Corporation

Selection Table for Filters

SAND FILTERS										
Tank size	Control Type	Service Flow	Back wash Flow	Pressure drop-Media	Pressure drop-Valve	Total Pressure Drop	Pipe Size	Filter Media loading	Tank Area	Fineness of Filtering
Inch		(m <sup>3</sup> /hr)	(m <sup>3</sup> /hr)	psi	psi	psi	Inch	cu.ft	ft <sup>2</sup>	microns
10	263	1.9 - 3	3	04-8	2-4	6 - 12	1	1	0.55	8-10
12	263	2.7 - 4.5	4.5	04-8	3-5	7 - 13	1	2	0.79	8-10
14	263	3.6 - 6	6	04-8	4-7	8 - 15	1	3	1.07	8-10
16	180	4.8 - 8	8	04-8	2.5-6	6.5 - 14	1.5	4	1.4	8-10
18	180	6.0 - 10.0	10	04-8	4-7	8 - 15	1.5	5	1.77	8-10
18	Magnum	6.0 - 10.0	10	04-8	1.3-2.25	5.3-10.25	1.5	5	1.77	8-10
21	Magnum	8.2 - 13.6	13.6	04-8	1.8-3	5.8 - 11	1.5	6	2.41	8-10
24	Magnum	10.7 - 17.8	17.8	04-8	2.4-4	6.4 - 12	2	9	3.14	8-10
30	Magnum	16.7 - 28	28	04-8	3.75-6.3	7.75 - 14.3	2	14	4.91	8-10
14	Aqua Kit	3.6 - 6	6	04-8	0-2.5	4 - 10.5	1	3	1.07	8-10
16	Aqua Kit	4.8 - 8	8	04-8	0-0	4 - 8	1.5	4	1.4	8-10
18	Aqua Kit	6.0 - 10.0	10	04-8	0-1.5	4 - 9.5	1.5	5	1.77	8-10
21	Aqua Kit	8.2 - 13.6	13.6	04-8	0-0.5	4 - 08.5	1.5	6	2.41	8-10
24	Aqua Kit	10.7 - 17.8	17.8	04-8	0-1	4 - 09	2	9	3.14	8-10
30	Aqua Kit	16.7 - 28	28	04-8	0-1.5	4 - 09.5	2.5	14	4.91	8-10
36	Aqua Kit	24.0 - 40.0	40	04-8	0-1	4 - 09	3	20	7.07	8-10
42	Aqua Kit	32.8 - 54.5	54.5	04-8	0-2	4 - 10	3	28	9.62	8-10
48	Aqua Kit	43.0 - 71.0	71	04-8	1.5-4	5.5 - 12	3	34	12.56	8-10
54	Aqua Kit	54.0 - 90.0	90	04-8	0-2	4 - 10.5	4	43	15.9	8-10
60	Aqua Kit	66.0 - 110.0	110	04-8	0-2.5	4 - 10.5	4	53	19.63	8-10

Service flow higher than that shown in the table can be achieved at an increased pressure loss ( $\Delta p$ )



# 6- WATER CHILLER

## Domestic Water Chiller

Domestic Water Chillers are compact chillers as they occupy lesser space. These chillers are best suited for individual or small villas and apartments.

Connected to the main storage tank, Domestic Water Chillers cool water effectively even during peak summers. The set-up is similar to the Overhead Tank Chiller and accessories like pump, stainers and flow-switches are provided separately, if required. The water is cooled to 28° C to 30° C and can be used for a host of applications in bathrooms, kitchens and other outlets.

### Features

- ▶ Wide range of models: 1.5, 2, 2.5, 3 & 3.5 TR
- ▶ Extremely compact
- ▶ Connects effortlessly to existing water treatment system
- ▶ Anti-corrosive hydrophilic coated fins for extended life
- ▶ Pure polyester power coated cabinet for UV protection
- ▶ \*R407C Option



### Technical Specifications

Models	Unit	DWCR 1018	DWCR 1024	DWCR 1030	DWCR 1036	DWCR 1042
Tank capacity to be cooled	Gallon	1000	1500	1700	2150	3000
Power Supply	V/Ph/Hz	230/1/50	230/1/50	230/1/50	230/1/50	400/3/50
Unit Dimention - L x D x H	mm	1016 x 406 x 686	1016 x 406 x 686	1016 x 406 x 686	1016 x 406 x 990	1016 x 406 x 996
Refrigerant		R 22				
Refrigerant Qty	kg	1.2	1.7	2.5	3.1	3.5
Weight	kg	75	82	88	92	102
Compressor Details		Hermetic Reciprocating				
Capacity, Btu/hr @35° C/46° C Ambient	Btu/hr	15150/12225	19500/15900	23175/19425	29775/25050	39100/32900
Full Load						
Current@35° C/46° C Ambient	Amp	9.1/9.7	9.5/10.5	11.6/13.2	13.2/15.3	5.9/6.5
Input Power@ 35° C/46° C Ambient	kW	1.8/2.0	2.0/2.2	2.4/2.7	2.6/3.1	3.2/3.7
Fan Details						
Diameter/Qty	mm/no.	508/1	508/1	508/1	610/1	610/1
Fan Motor		Direct Driven, Totally Enclosed				
Power / Qty	hp/no.	1/4 hp/1	1/4 hp/1	1/4 hp/1	1/3 hp/1	1/3 hp/1
Water Connections-Intel/Outlet	Inch	1"/1" Bsp	1"/1" Bsp	1"/1" Bsp	1"/1" Bsp	1"/1" Bsp
Water Leaving Temperature						
Overating Range	° C	20~30	20~30	20~30	20~30	20~30

Rating Conditions: The rating are based on 28° C chilled water outlet and 35° C / 46° C ambient temperature.

\*Models DWCR1024 & DWCR1036

Specifications are subject to change due to continuous product development

# Our Clients

Solution as you need



CONTRACTORS	PROJECTS
AL-TAHRIR TRADING	8 BUILDING AT MUNTAZAH
ICON GENERAL CONTRACT	ALUMCO AT INDUSTRIAL AREA
BOOM CONSTRUCTION CO	UMM SAIEED CAMP
POWER SYPPLY TRADING CO	OLD AL-GAHNIM
AL-WAJEAA TRADING	BERKAT AL-AWAMER
AL-TAHRIR TRADING & CONT	DASMAN
LARISSA GARDINGS	PERAL QATAR
ASYAD QATAR	2B+G+6 AT AL-SADD
POWER SUPPLY TRADING	QATAR UNIVERSITY
DESERT GROUP CO	AL-WJBA PALACE
GOULF TRADING	54 VILLA AT AL RAYYAN
AL-JALIL TRADING	P. 11 MADINAT KHALIFA
AL WABARA FARM	AL WABARA FARM
EL ETIHAD STEEL FACTORY	EL ETIHAD STEEL FACTORY INDUSTRIAL AREA
AHMED BIN MOHAMED COLDGE	AHMED BIN MOHAMED COLDGE
KHALID BIN AL WALID SCHOOL	KHALID BIN AL WALID SCHOOL
AL-TAADD GROUP	PARWA PROJECT
HAMTON INTERNATIONAL	AL BEDAA SWITCH GAR FACTORY
MIRDAS	RASS LAFFAN
GAZZAOUI & PARTNRS	14 VILLAS PROJECT
AMTC ABDULLA AL MUFTAH	PERAL QATAR
T.E.A FOR MECHANICAL	50 VILLA AIN KHALID
ISKAN GROUP	SHAHANYA LABOUR CAMP
RED LINE	OLD AIRPORT



# MEP

ENGINEERING  
ELECTRO MECHANICAL W.L.L  
MECHANICAL - ELECTRICAL - PLUMBING

